

# TEKSTYLE® Roll-Up Tonneau Cover Installation Guide

## Contents:

- (1) Cover Assembly
- (1) Driver's Side Rail (US)
- (1) Passenger Side Rail
- (1) Clamp Kit
- (1) 5/32" Hex Key
- (1) 3/32" Hex Key

Tools Required (most applications):  
Tape measure

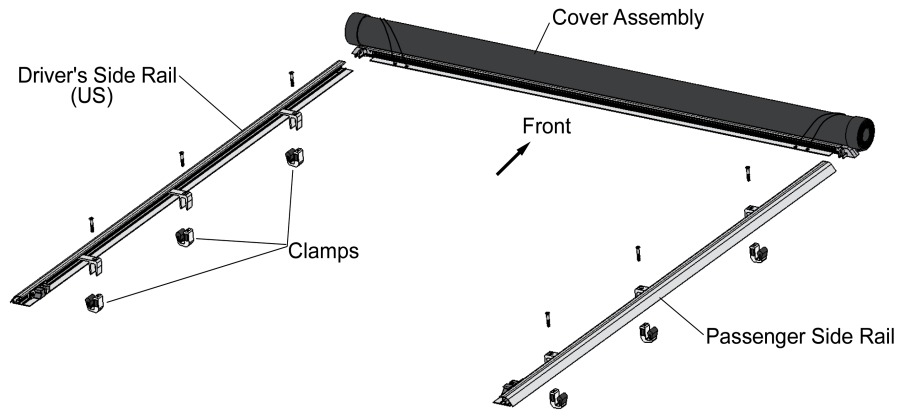

## 1. Clean top of bed

## 2. Set side rails onto truck

Set side rails onto truck making sure Tensioners face the rear.

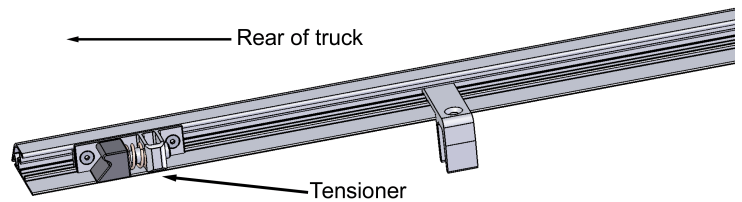

## 3. Attach cover assembly to side rails



Attach front rail of cover assembly by sliding corners into side rails until they snap into place.

Align frame from front to rear and side to side.

## 3. Align frame

For proper latching, the ends of the two side rails must be properly spaced before connecting the clamps.

The distance is printed on the sticker located at the rear of the driver's side rail. (Measure across the far inside edges of the two rails).

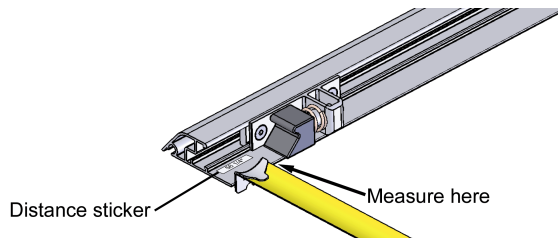

## 5. Install clamps

The upper clamps are pre-installed on most kits...If side rails are notched out at the clamp locations, install the upper clamps by inserting them from the side (see illustration at left).

Connect the lower portion of the clamps under the lip of the truck bed. If clamp sizes differ, place smaller clamps to the center of the bed.

Re-check rear distance & tighten clamps with supplied hex key.

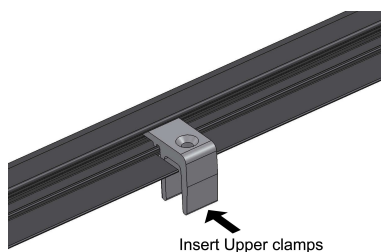

## 6. Fasten vinyl cover

1) Set rear rail into tensioner

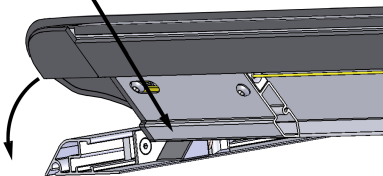

2) Rotate down & latch

- 1) Stretch both bungee straps past front tabs to release the rolled cover.
- 2) Unroll cover completely toward rear of bed.
- 3) Set rear rail down into the tensioner at the ends of each side rail.
- 4) Rotate downward from above until both latches click closed. Lift upwards at both ends to check for proper latch engagement.
- 5) Seal Hook & Loop along both sides of cover, lifting and pressing if needed to align edge.

**Never drive without both rear latches fully engaged!**

## 7. To open & stow vinyl cover



- 1) Open tailgate & pull down on center release strap to release latches.
- 2) Roll cover towards the front (the bows will roll up inside the cover).
- 3) Once near the front, secure both bungee straps by stretching them over the front tabs. (do not allow the cover to rub against the back of the cab as it can wear the paint).

## 8. Adjustment

**To adjust, loosen both screws on each tensioner, slide mechanism forward / back. Re-tighten screws.**

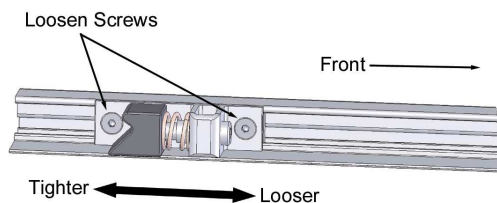

Tension is pre-set from the factory, however it may be necessary to adjust the tension of the vinyl, looser if the cover is difficult to secure, or tighter if water accumulates on the cover. Mark original location before making any adjustments.

Note: Cover may accumulate a small amount of water if hook and loop along sides is not adequately secured.

**Warning: If the tension is set too tight, damage to the cover may result.**

## 9. Warranty Card

Please fill out the enclosed warranty card and mail it within 30 days of purchase to activate your Tonneau Cover warranty.

## 10. Bedliner installation:

To install with an under-the-rail style, the bedliner may need to be trimmed back at the clamp locations and possibly along the front to allow for the front rail to seal properly. Over-the-rail liners may require additional modifications to ensure solid clamping.